



CQPUSI ROBOT CONTROL SYSTEM

ROBOTDIGG & JUGETEK

# User Manual

---

PMD006xx Series

Miniature Integrated Stepper Motor Driver

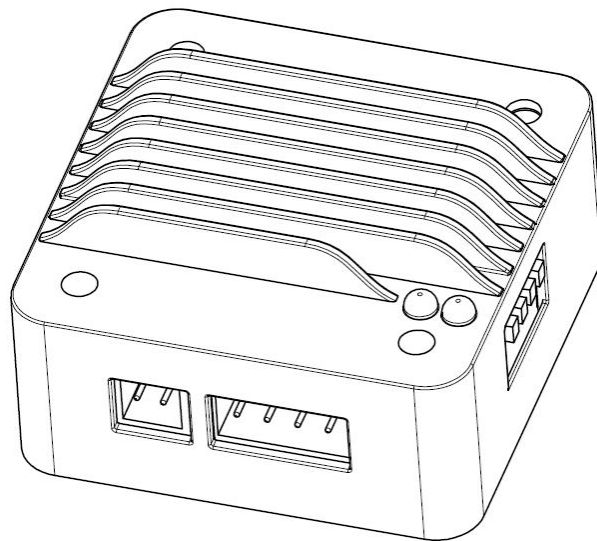



Catalog

1	Introduction.....	4
1.1	Statement of intellectual property right.....	4
1.2	Disclaimer.....	4
2	Overview.....	5
2.1	General Description.....	5
2.2	Features.....	5
2.3	Product selection & Ordering Information.....	5
3	Connection description.....	6
3.1	Terminal port location.....	6
3.2	Motor connection J2.....	6
3.3	Power connection J3.....	6
3.4	Signal connection J1.....	6
3.5	Operation current adjustment knob S1.....	7
3.6	Idle current adjustment knob S2.....	7
3.7	Microstepping and selection of pulse dial switch S3.....	7
3.8	Indicator Led.....	8
4	Signal connection of driver.....	8
4.1	Common cathode connection.....	8
4.2	Common anode connection.....	8
4.3	Differential connection.....	9
4.4	Encoder following.....	9
4.5	Selection of divider resistance.....	10
5	Interface timing.....	10
6	Electrical Characteristics.....	11
7	Dimensions.....	11

## **1 Introduction**

### **1.1 Statement of intellectual property right**

PMD006xx series driver has been applied for the following national patent:

- Controller scheme and method have been applied for the protection of the invention patent.
- Controller circuit has been applied for the protection of utility model patent.
- Controller appearances has been applied for the protection of appearance patent protection.

Since PMD006xx series controller with embedded firmware code, it would be considered as a violation of intellectual property protection act and regulations that any behavior of trying to destroy the function of the firmware code protection. If this behavior acquires the software or other achievements of intellectual property protection without authorization of CQPUSI, CQPUSI has the right to stop such behavior by filing a lawsuit according to the act.

### **1.2 Disclaimer**

The using method of the device and other content in the description of this manual is only used to provide convenience for you. To ensure the application conforms to the technical specifications is the responsibility of your own. CQPUSI does not make any form of statement or guarantee to the information, which include but not limited to usage, quality, performance, merchantability or applicability of specific purpose. CQPUSI is not responsible for these information and the consequences result caused by such information. If the CQPUSI device is used for life support and/or life safety applications, all risks are borne by the buyer. The buyer agrees to protect the CQPUSI from legal liability and compensation for any injury, claim, lawsuit or loss caused by the application.

## 2 Overview

### 2.1 General Description

PMD006xx is a kind of miniature integrated stepper motor driver, which can be directly installed in the rear 42/57/86 etc series bipolar stepper motor, and which has the advantages of small size, strong driving force, and low heat and so on. PMD006xx stepping motor driver can provide 0~5A continuous adjustable peak current, maximum 16 microstepping, idle current also can be adjusted continuously.

### 2.2 Features

- ✓ Wide range of 8-35V single voltage supply.
- ✓ Output current 0.5A ~ 4A, which can be adjusted continuously.
- ✓ Support common anode, common cathode, differential, double pulse, pulse direction, and other input modes.
- ✓ Support 0/2/4/8/16 microstepping mode.
- ✓ Support 4/6/8 lines of 2 phase bipolar stepper motor.
- ✓ The highest frequency of input pulse can reach 250 KHz.
- ✓ TSD, UVLO, OCP built in protection.
- ✓ The idle current can be adjusted from zero to full load continuously.
- ✓ Support full torque mode for torque enhancement.
- ✓ Ultra fast response to external pulse input.
- ✓ Support 0/2/4/8/16/32/64/128 microstepping mode. ( Only PMD006P2 )

### 2.3 Product selection & Ordering Information

In order to serve you quicker and better, please provide the product number in following format when ordering.

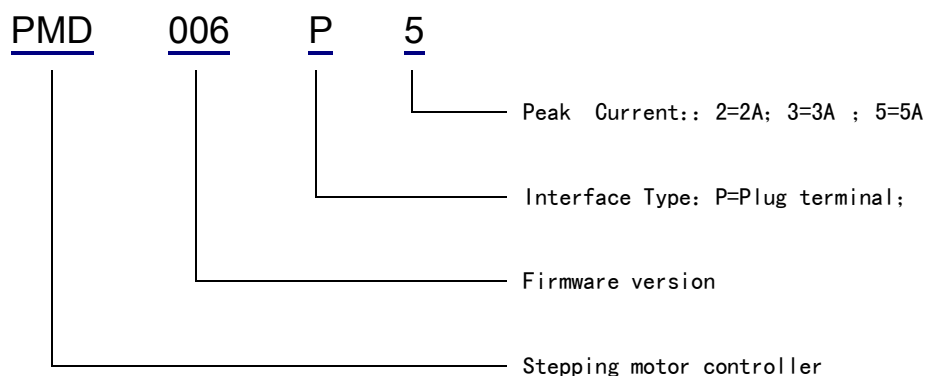

### 3 Connection description

#### 3.1 Terminal port location



图 3-1

#### 3.2 Motor connection J2

Pin no:	1	2	3	4
Designator:	M10	M11	M20	M21

Description:

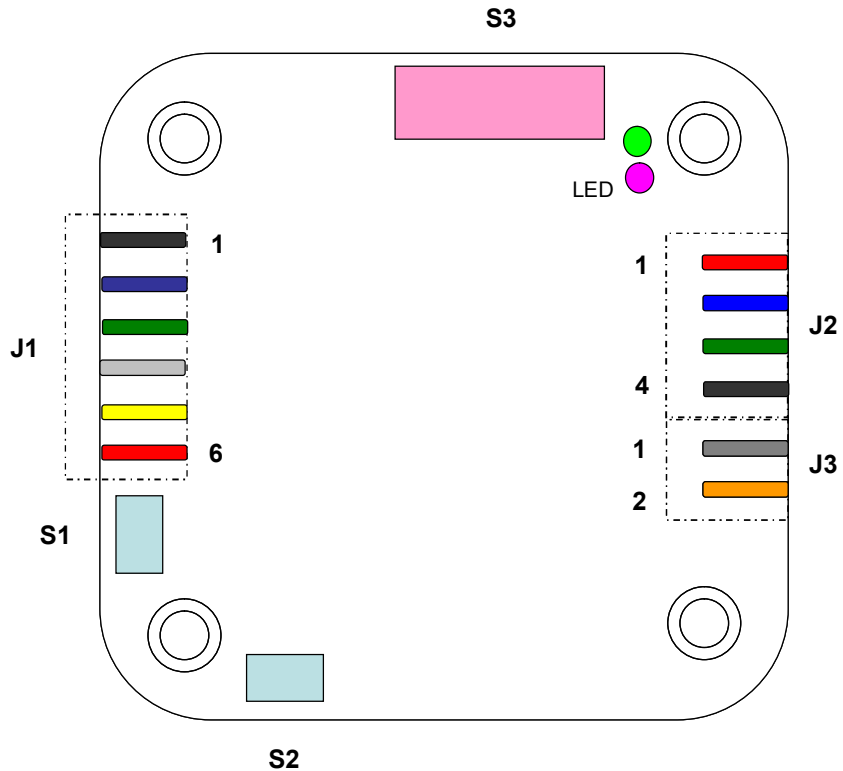
M10, M11: Connect to the stepper motor phase A;

M20, M21: Connect to the stepper motor phase B.

**WARNING:** Incorrect connection of phase of power or motor will permanently damage the controller!

#### 3.3 Power connection J3

Pin no:	1	2
Designator:	GND	VCC

Description:

VCC: DC supply voltage, 8~35V;

GND: Supply voltage ground.

#### 3.4 Signal connection J1

Pin no:	1	2	3	4	5	6
Designator:	ENA+	ENA-	PUL+	PUL-	DIR+	DIR-

Description:

ENA+/-: Enable signal, optocoupler input. Don't enable when conduction;

PUL+/-: The pulse signal, optocoupler input;

DIR+/-: The direction (or pulse) signal, optocoupler input;

Notice: The voltage directly added on the optocoupler inputs should not exceed 5.5V. When the value of input signal exceeds 5V, the extra divider resistance is required.

### 3.5 Operation current adjustment knob S1

It is used to adjust the operation current of driver. The 0~5A current can be adjusted continuously.

Notice: There is not linear proportion relationship between mechanical stroke of potentiometer and current value. Please refer to the scale indicator to determine the value of current.

### 3.6 Idle current adjustment knob S2

It is used to adjust the idle current of driver. The minimum value is 0, and the highest value is the value of operation current which can be adjusted continuously.

Notice:

1. There is not linear proportion relationship between mechanical stroke of potentiometer and current value. Please refer to the scale indicator to determine the value of current.
2. If PUL+/- of optocoupler is in a conduction state, the driver will be out of idle mode even if there is no pulse forming. The users can dynamically control the holding torque because of this feature. If users do not want to use this feature, just ensure PUL+/- (including DIR+/- in double pulse mode) in spare time is in a non conducting state.

### 3.7 Microstepping and selection of pulse dial switch S3

Dial switch 1~3 is used to select the microstepping of driver. Dial switch 4 is used to select pulse/ direction operation mode or dual pulse operation mode.

SW1	SW2	SW3	Function	Remarks
OFF	OFF	OFF	0 Microstepping	
ON	OFF	OFF	0 Microstepping	Full torque mode
OFF	ON	OFF	2 Microstepping	
ON	ON	OFF	2 Microstepping	Full torque mode
OFF	OFF	ON	4 Microstepping	
ON	OFF	ON	8 Microstepping	
OFF	ON	ON	16 Microstepping	
ON	ON	ON	Reset	Self tuning

SW4: ON: set the dual pulse input mode, OFF: set the pulse / direction input mode.

Notice: In addition to the reset function, the selection of the dial switch should be switched on before the power is on.

The following is to set PMD006P2:

SW1	SW2	SW3	Function	Remarks
OFF	OFF	OFF	0Microstepping	
ON	OFF	OFF	2Microstepping	
OFF	ON	OFF	4Microstepping	
ON	ON	OFF	8Microstepping	
OFF	OFF	ON	16Microstepping	
ON	OFF	ON	32Microstepping	
OFF	ON	ON	64Microstepping	
ON	ON	ON	128Microstepping	

### 3.8 Indicator Led

There are two lights on the top of PMD006xx driver. The green light is the normal power indicator, and the red light is error indicator. The red light is on when driver is in the state of reset, over voltage, over temperature, or over current.

## 4 Signal connection of driver

PMD006 series driver support the connection of common cathode, common anode, differential, single/double pulse, encoder following and so on.

Details are as follows.

### 4.1 Common cathode connection

Figure 4-1 provides a common cathode connection method. The current flows from the signal+ port of driver, and pours into the ground of controller from signal- port. The resistor R can be omitted when the output voltage of the controller is less than 5V.

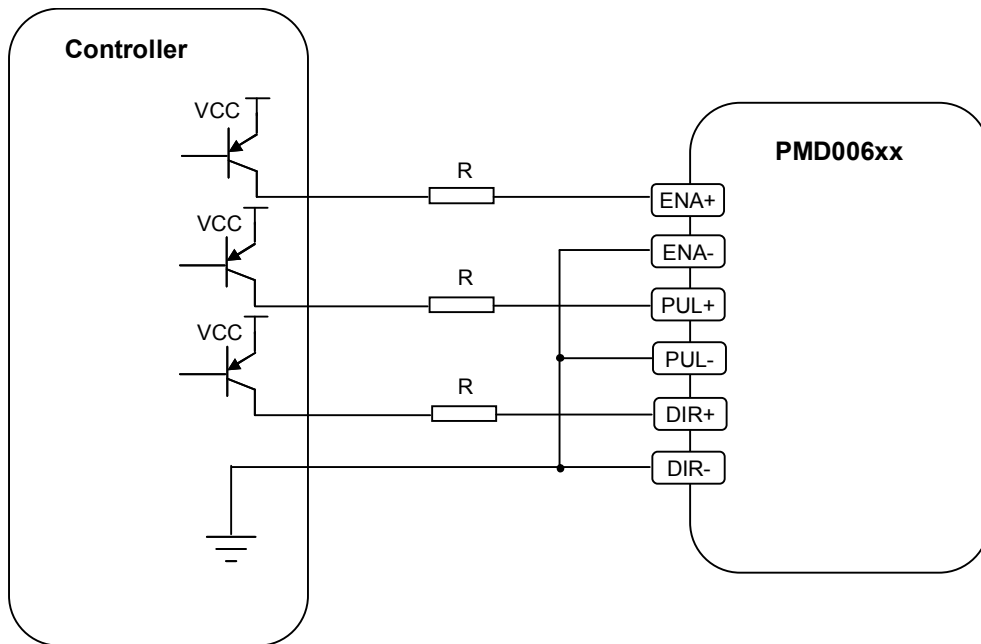

Figure 4-1

### 4.2 Common anode connection

Figure 4-2 provides a common anode connection method, which is suitable for connecting controller with the open collector type output such as PI0002xx. The resistor R can be omitted when the output voltage of the controller is less than 5V.



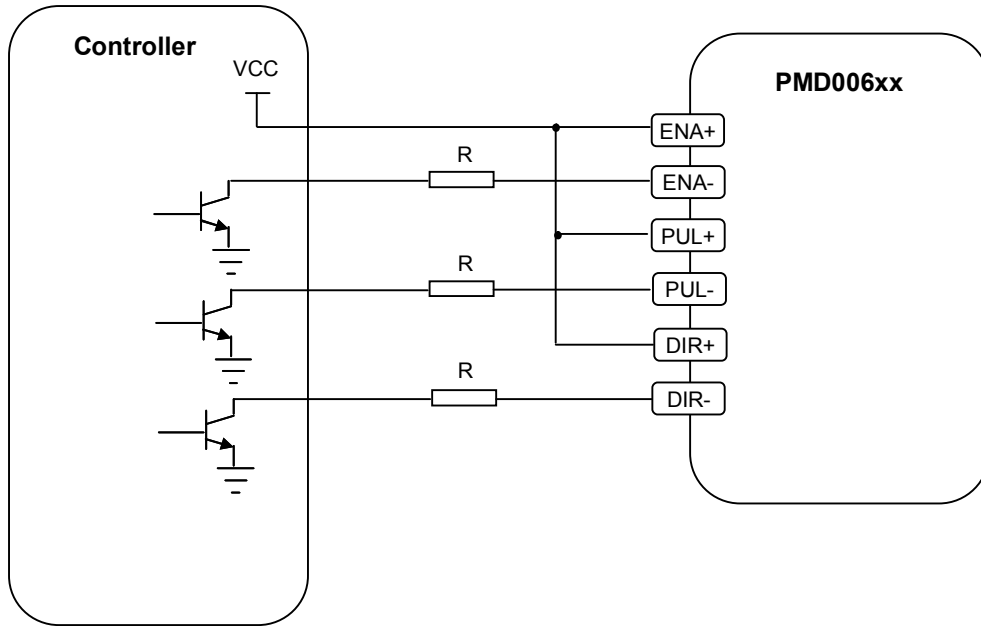

Figure 4-2

### 4.3 Differential connection

Figure 4-2 provides a differential connection method. Using long-wire differential driver in the harsh environment can significantly improve the transmission distance and anti-jamming ability of the signal. The typical differential driver uses RS422 driver chip to work.

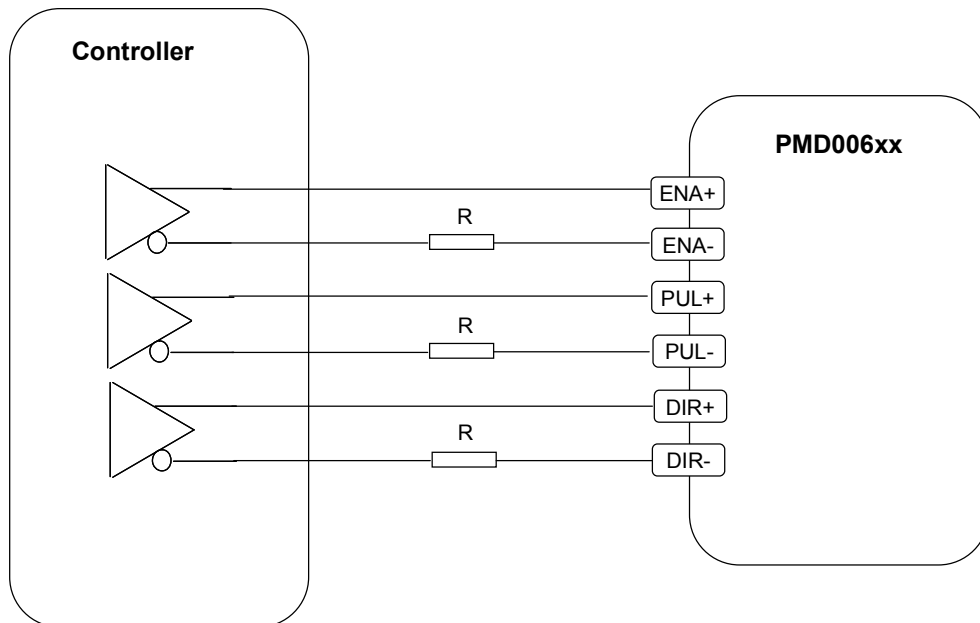

Figure 4-3

### 4.4 Encoder following

In order to achieve the following function, the PUL and DIR interface of PMD006xx can be connected to the output of encoder, graduator or hand wheel of CNC. In this application,

the SW4 of dial switch S3 must be set ON. If there is already the phase detector circuit on the output terminal of encoder, the encoder can be directly connected to the PUL and DIR ports. Otherwise the PEN2CCW sub module is required to connect encoder and driver, as shown below.

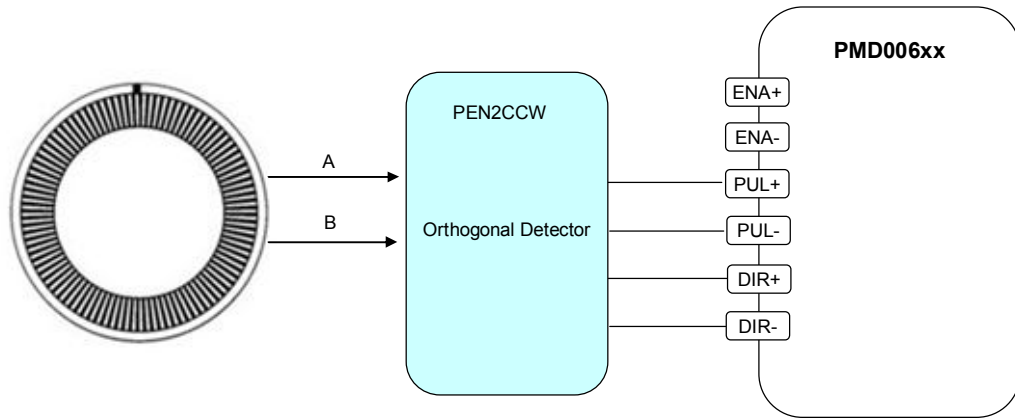

Figure 4-4

#### 4.5 Selection of divider resistance

The maximum voltage which the signal interface of PMD006xx can directly bear is 5.5V. In most cases, the output voltage of controller may exceed this value. Such as, the output voltage of PI0002xx or PLC is generally 24V. In this case, in order to make the current flowing through the emission port of optocoupler less than 18mA, a divider resistance should be connected on the signal circuit. Normally, the 1.5Kohm 1/4W resistor is recommended to use when 12V voltage inputs. The 3.3Kohm 1/4W resistor is recommended to use when 24V voltage inputs.

### 5 Interface timing

The signal of PMD006xx interface is required to meet the following timing. (The committed value is minimum)

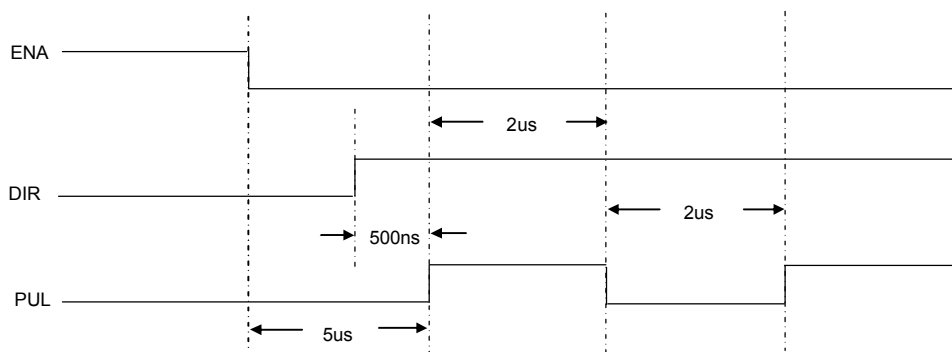

Figure 5-1

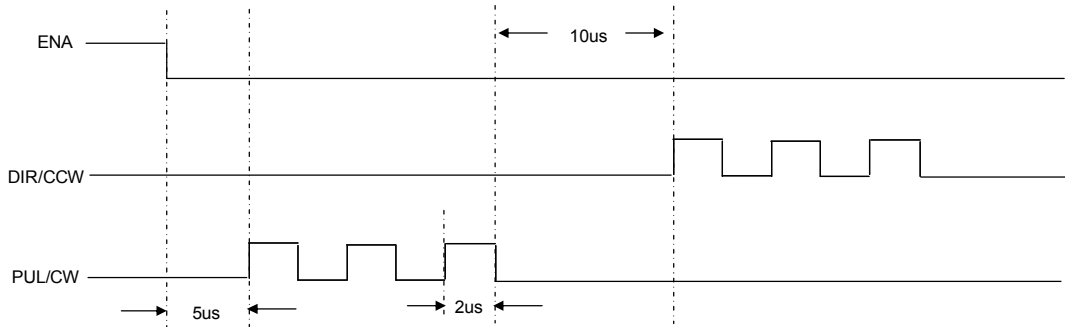

Figure 5-2

## 6 Electrical Characteristics

Parameter	Condition	Min	Typical	Max	Unit
Power Voltage	Normal 25°C	8		35	V
Temperature	24V DC	0		55	°C
IO maximum current	Source/sink current	0		20	mA
Output current	Normal 25°C	0		5	A
Input pulse frequency	24V DC voltage	0		250	KHz
Speed range	0 Microstepping	0		4000	RPM
Idle current range	3A operation current	0	Adjustable	3	A

## 7 Dimensions

